



Product Information

Accuracy: ±3% F.S.
Rating: 240 psig at 250° F (1655 kPa at 120° C)
Venturi:
Body: Steel ASTM - A120
Instrument Valves: Extended SuperSeal P / T Test Ports
Design: Low loss, piezo-ring throat
Butterfly Valve:
Body: Ductile Iron, full-lug type body
 ANSI Class 125/150
Seat & Gasket: EPDM
Stem: Stainless Steel
Bearings: Nylon
Disc: Stainless Steel

The AccuSetter uses a low-loss venturi to obtain a measurement accuracy of 3% F. S. The venturi and downstream butterfly valve have been matched and laboratory tested to verify the accuracy. The butterfly has a 2" extended neck above the flange for insulation. The valve handle has an infinite-position memory stop for sizes 2" to 6" and a gear operator on 8" to 16" sizes. The total pressure drop added to the pump head seldom exceeds one foot. The exact drop can be calculated using the formula on Form F199. **Flow measurement** can be obtained with a differential pressure meter reading across the venturi taps. The GPM can be calculated using the formula on Form F199. (See "Flow Measurement Test Kits," form F011 for the differential pressure meter kits.) The **design flow** can be obtained by adjusting the valve operator until the desired GPM is reached. The set handle position is maintained by using the memory stop.

Dimensions not to be used for construction unless prints certified by factory.

Dimensions (inches) & Weights (pounds)

Model	Size	Connections	A	B	C	D	Weight
AG0200(*)	2"	Grooved	10.5	6.0	6.6	10.0	19.3
AF0200(*)		150# Flange	8.3	6.0	6.6	10.0	20.6
AW0200(*)		Welded	7.65	5.6	7.0	9.0	15.0
AG0250(*)	2 1/2"	Grooved	10.7	7.0	7.2	10.0	25.2
AF0250(*)		150# Flange	8.3	7.0	7.2	10.0	27.6
AW0250(*)		Welded	7.9	5.47	7.3	9.0	22.0
AG0300(*)	3"	Grooved	11.3	7.5	7.6	10.0	34.0
AF0300(*)		150# Flange	10.9	7.5	7.6	10.0	35.0
AW0300(*)		Welded	10.5	6.0	8.0	9.0	27.0
AG0400(*)	4"	Grooved	14.3	9.0	8.4	10.0	53.0
AF0400(*)		150# Flange	13.9	9.0	8.4	10.0	53.7
AW0400(*)		Welded	13.5	7.5	8.3	9.0	45.0
AG0500(*)	5"	Grooved	14.9	10.0	9.0	10.0	61.3
AF0500(*)		150# Flange	14.5	10.0	9.0	10.0	64.7
AW0500(*)		Welded	14.3	8.47	8.85	9.0	52.0
AG0600(*)	6"	Grooved	15.6	11.0	9.7	10.0	78.6
AF0600(*)		150# Flange	15.1	11.0	9.7	10.0	86.6
AW0600(*)		Welded	14.63	9.5	9.3	9.0	71.5
AG0800(*)	8"	Grooved	16.6	13.5	7.5	8.0	123.3
AF0800(*)		150# Flange	16.0	13.5	7.5	8.0	135.7
AW0800(*)		Welded	15.75	11.7	17.4	5.0	117.5
AG1000(*)	10"	Grooved	18.1	16.0	7.5	9.0	178.3
AF1000(*)		150# Flange	17.4	16.0	7.5	9.0	194.5
AW1000(*)		Welded	16.83	14.25	17.4	5.0	167.5
AG1200(*)	12"	Grooved	20.3	19.0	7.5	9.0	279.6
AF1200(*)		150# Flange	19.5	19.0	7.5	9.0	307.0
AW1200(*)		Welded	19.5	17.0	19.1	6.0	261.5
AG1400(*)	14"	Grooved	26.9	21.0	11.8	9.0	399.3
AF1400(*)		150# Flange	21.6	21.0	11.8	9.0	372.9
AW1400(*)		Welded	20.5	19.0	21.0	10.0	379.5
AG1600L	16"	Grooved	27.8	16.0	11.8	9.0	550.9
AF1600L		150# Flange	22.5	23.5	11.8	9.0	539.9
AW1600L		Welded	22.7	21.25	26.2	10.6	529.9

Notes

* Denotes L (low flow) or H (high flow) must be specified. All weights and dimensions given are in pounds and inches and are subject to change.

Venturi products made from fabricated materials may vary ±1/16 inch per component.

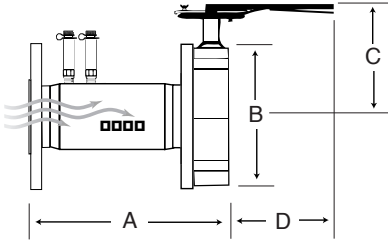

Model AF

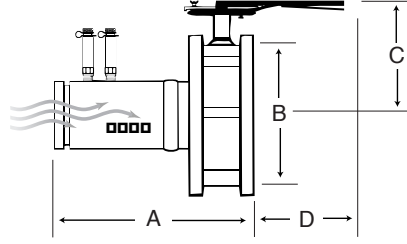

Model AG

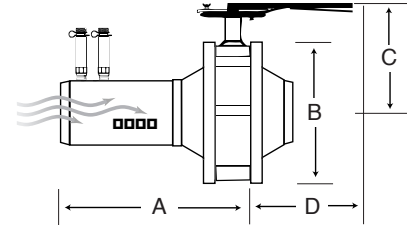

Model AW

Model Information

Model AF AccuSetter includes a flanged venturi with a lug butterfly valve attached to the downstream side. Extended SuperSeal Pressure/Temperature Ports are standard.

- *Field installation requires one 150# mating flange. Cap screws are included to mate the butterfly and the customer-supplied flange.*

Model AG AccuSetter includes a grooved venturi on the entry with a lug butterfly valve mounted on the downstream exit end and a Model GF 150# grooved adapter flange with cap screws, supplied loose, for attachment to the butterfly valve and downstream grooved pipe. The Model FG is also available as an option on all sizes. Extended SuperSeal Pressure/Temperature Ports are standard.

- *Field installation requires one standard grooved coupling for the upstream attachment.*

Model AW AccuSetter includes a weld-end venturi on the inlet with a lug type butterfly valve mounted to the downstream venturi flange and a 150# weld-end flange mounted to the butterfly valve. Pressure access ports are standard. The unit is shown with optional extended P/T plugs.

- *Field installation requires no additional material.*

Supplemental Installation Instructions

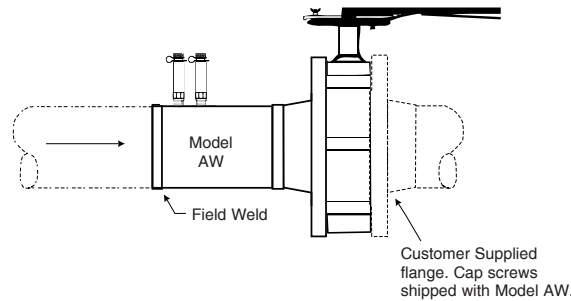

See *Venturi & AccuSetter Valves Installation, Operation & Maintenance (F033)* for more information.

Model Order Designation

Model / Size
4"/DN 100 AG Shown

AG0400L - MI

Flow Range
Low Flow Range Shown

L = Low Flow Range H = High Flow Range

Options
Use for options that have specific locations.
Metal ID Tag Shown

Options Available

AV Manual Air Vent

C2 1/2" Accessory Port

C3 3/4" Accessory Port

C4 1/4" Accessory Port

FG Grooved Accessory Flange

HN Hose End Drain

PI Plastic ID Tag

SE Stem Extender