

Contents

Contents

- Unpacking2
- Initial Piping and System Flushing3
- Final Piping4
- Balancing5

Automatic
Manual Venturi
Manual P/T

- Operation and Maintenance6
- Trouble Shooting7
- Warranty8



Typical Self-Balancing Hose Kit (Kit A)

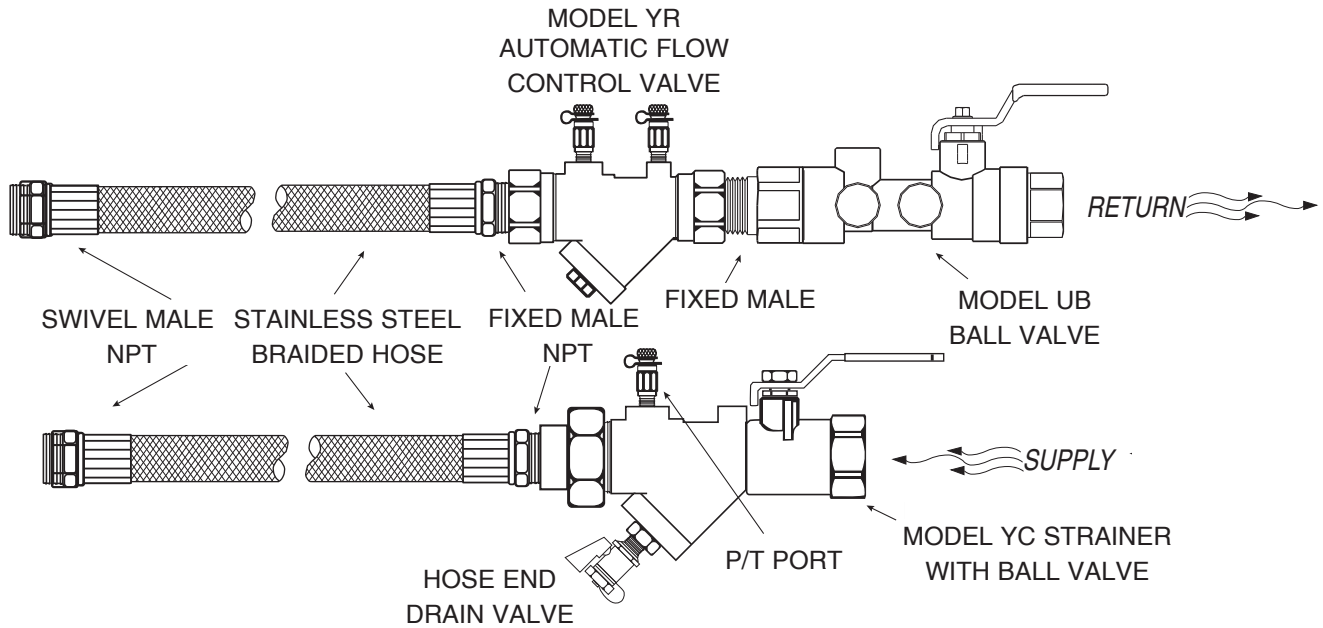

Typical Venturi-Balancing Hose Kit (Kit B)

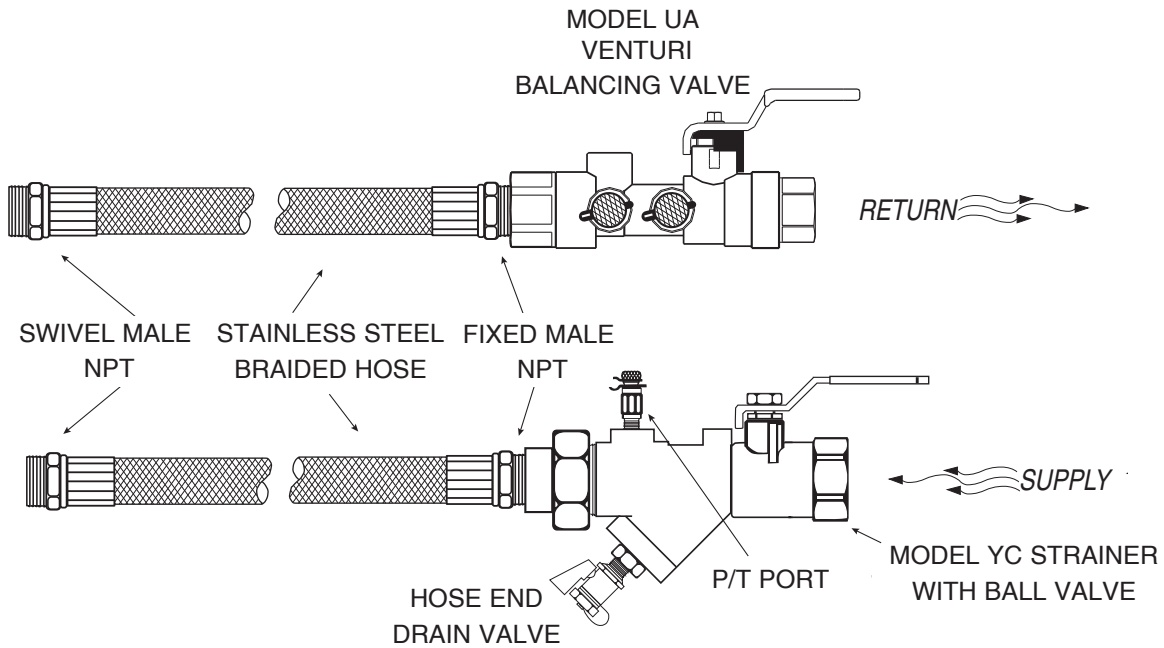

Unpacking

1. Using the "Bill of Material," verify that all components have been shipped. Your kit may be different than the typical ones shown above.
2. Check the unit tagging. Many times "Hose Kits" are not interchangeable. One 3/4" unit can be different from another 3/4" unit.

Initial Piping and System Flushing

There can be dirt and debris in the system piping which should not be allowed to enter the coil strainer, the coil or the balancing valve. The use of aggressive cleaning and flushing agents should be avoided. The following steps for initially piping the “Hose Kits” will protect the coil, strainer and balancing valve from being contaminated during flushing.

1. Install the isolation (ball) valves and connectors for the heat pump. The ball valves are shipped with hand-tight connections.
 - A. When installing sweat connected valves, clean both copper tube and valve ends with emery cloth and apply flux uniformly. Use soft solder and direct the flame alternately between the tubing and valve connection. Do not apply the flame directly to the center of the valve body because excessive heat can cause damage to the valve seals. Ball valves are to be placed in the closed position when soldering place. After the solder begins to melt, remove flame and continue to apply solder until a ring forms completely around the circumference of the joint. Remove excess flux and solder while the joint is still hot. Use a damp cloth over the body of the valve as a heat sink to prevent overheating.
 - B. P/T plugs, air vents and blowdown/drain valves are factory installed with “PTFE,” an anaerobic Teflon filled pipe sealant, and will withstand soft solder temperatures when the valves are “heat-sinked.” If these units should leak upon pressure test, remove and re-install with new sealant.

Caution: Do not tighten under fluid pressure.
 - C. Install the fitting adapters to the “Heat Pump.” Hand-tighten the swivel nuts on the hose

2. Hose Check List.

- A. The hoses are shipped with the swivel connections hand-tight to simplify installation.
- B. Do not exceed the minimum bend radius shown for each hose.

Caution: If the hose assemblies have been stored below 40° F, or are being installed in these conditions, the minimum bend radius should be increased by 50% and care should be taken not to collapse the hose.

Hose Size	1/2”	3/4”	1”	1 1/4”	1 1/2”	2”
Min. Radius	5”	7”	7”	8”	9”	10”

- C. Use the drawings below as a guide for proper installation. The hose may change in length 4% under pressure therefore, it is necessary to provide sufficient slack for expansion and contraction. Do not bend the hose across the face of the fitting as shown in figure 2, it may cut the inner tube. The use of proper angle adapters should be made to avoid sharp twists or bends in the hose. It is essential to maintain the bend radius on the installed hose at least equal to or greater than the recommended minimum bend radius to ensure proper flow path and for longer life of the hose. It is important to ensure the the flexible hose will not become twisted or kinked during installation. Swivel connections should be fastened only after the fixed connections have been fastened first. Also, after the swivel connections are tightened, it should be ensured that fixed connections are not tightened further as this may cause twisting and damage the hose. (See page 4)

Initial Piping and System Flushing (Cont'd)

Figure 1

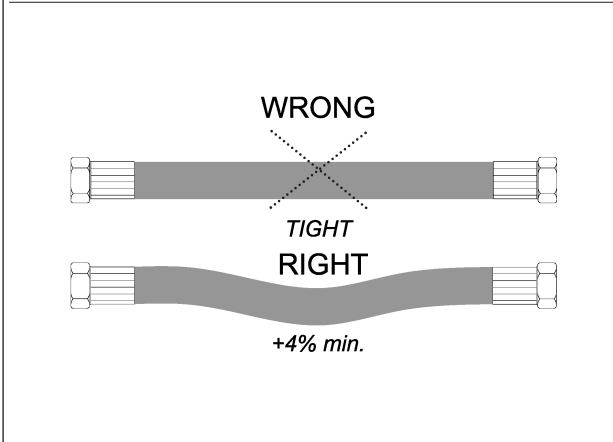
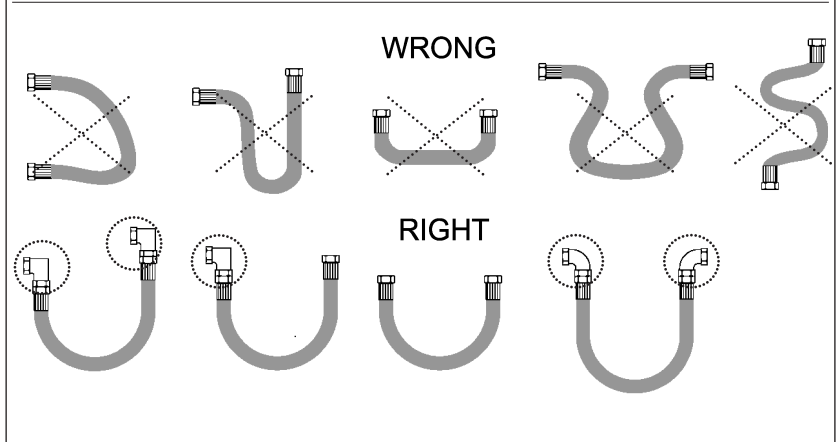
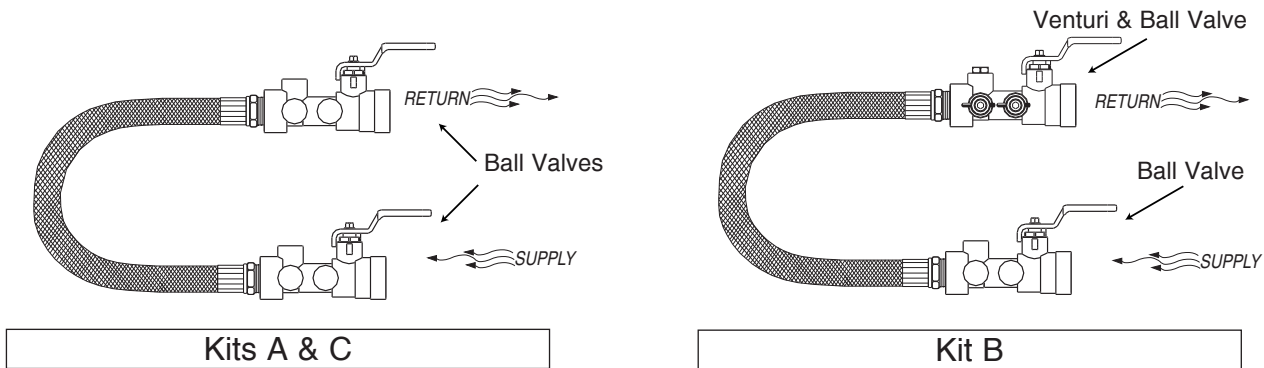

Figure 2



Initial Piping and System Flushing

3. Before flushing, install one of the hoses so that it connects the supply and return isolation valves. See diagram below: *Both the hose ends have NPT threads and thus require the use of proper pipe dope or sealing tape.*



4. Do not over-torque the hose nuts. A good rule of thumb is finger-tight plus an additional one-quarter turn. All hoses have fixed male NPT threads on one side and swivel male NPT threads on the other side. It is essential to use pipe dope or sealing tape while assembling these end connections. Use two wrenches to tighten the nuts: one to hold the line and the other to tighten the nut. Do not turn fittings in the hose. Do not twist the hose. Sharp bends, kinking or twisting of the connector during installation must be avoided.

5. Open the isolation ball valves. **This unit is now ready for system flushing.**

Final Piping and System Flushing

1. After flushing, close the ball valves.
2. Install hoses and other equipment in the normal operating position.
3. Install the condensate and blowdown hose. Cut the clear vinyl blowdown line to the desired length and secure over the tee with a radiator clamp. Slope the condensate hose from the heat pump at 1/4" per foot minimum.

Balancing

There are three types of hose kits available: A, B, and C. Each has a different balancing procedure.

Kit A: Automatic Self-Balancing

1. The automatic flow control valve should be on the return side of the coil.
2. Check the flow arrow for proper direction.
3. The design GPM is shown on the unit label. This flow cannot be exceeded because the internal spring and piston of the flow cartridge maintain a constant flow regardless of inlet pressure.
4. To verify the flowing GPM, the differential pressure across the AutoFlow valve can be measured. The differential pressure (D.P.) should be higher than 2 psi and less than 32 psi (For 2-32 psi range). If it is not within these limits, see the Trouble-Shooting section. (A 5 - 60 psi range is also available which means the D.P. should be between those limits.)

Kit B: Venturi Manual Balancing

1. The venturi and throttling ball valve should be located on the return side of the coil.
2. The FlowSet venturi can measure the flow by measuring the differential pressure across the venturi taps.
3. The proper differential pressure (D.P.) is determined using the venturi flow chart in form F234.
Example: 10 gpm required with a 'B' body and venturi #6, would have 69.7 inches of D.P.
4. Adjust the ball valve on the return side of the coil until the desired D.P. is read on the meter.
5. Loosen the nut on the top of the valve handle and advance the memory stop until it hits the valve body. Re-tighten the nut while holding the handle and memory stop in place.

Kit C: Manual P/T Balancing

1. The differential temperature or pressure is best measured with one instrument used alternately on the supply and return side.
2. A 10° F to 13° F is commonly considered the optimum differential temperature (ΔT) for a "Heat Pump" on the cooling cycle. Consult the Heat Pump manufacturer's instructions for the correct value.
3. Place the thermometer in the supply side P/T port. Allow time for the reading to stabilize and make sure its compressor is operating.
4. Place the same thermometer in the return side P/T port.
5. Adjust the return side ball valve slowly until the desired ΔT is achieved.
6. Loosen the nut on the top of the valve handle and advance the memory stop until it hits the valve body. Re-tighten the nut while holding the handle and memory stop in place.
7. Differential pressure balancing can be accomplished in the same manner as temperature. The proper differential pressure is determined by calculation using the Cv of the heat pump coil.

Operation and Maintenance

1. Good maintenance practice dictates periodic hose inspections, typically when servicing other components such as motors, filters, etc. Look for small water leaks, residue, or discoloration on exterior braid or fittings. If a leak is detected, replace the hose. *Do not attempt to repair it in the field.*

Caution: *Introduction of chemicals into the loop may cause damage to the hose inner liner or stress corrosion cracks in the fittings. Consult a water treatment specialist before introducing chemicals, or call Flow Design if you are unsure of how to proceed. (1-800-ASK-FLOW)*

2. The inlet strainer should be checked or cleaned periodically. The time interval depends on experience and system conditions; every six months to two years is typical.
 - a. Back-flushing an inline or Y-strainer is accomplished by closing the supply ball valve and opening the blowdown valve. Usually ten seconds is enough to clean the strainer. Close the blowdown and open the supply valve to put the unit back into service.
 - b. Blowing down a Y-strainer is common, but the best method is back-flushing as described above.
 - c. The strainer may have to be manually cleaned if back-flushing fails to remove the debris. Shut-off the supply and return valves; drain the coil; remove, clean and replace the strainer basket; open the ball valves and vent the air from the coil.

VersaFlow Hose Kits

Installation, Operation and Maintenance Instructions

Troubleshooting Guide

Problem: Low Water Flow

Possible Cause	Possible Solution
1) Strainer Clogged	1) Back-flush or manually clean the coil strainer.
2) Wrong Location	2) Make sure the hose kit is in the proper location with the correct GPM.
3) System Pressure is Low	3) If possible, check the pressure at the hose kit supply and return valves. The drop through the coil and hose kit may be too large for the available head. The total pressure drop through the hose kit can be determined with brochure F318.
4) Balance Valve is Plugged	4) The AutoFlow valve may have debris. Remove cartridge, clean and replace.

Problem: High Water Flow

Possible Cause	Possible Solution
1) Wrong Location	1) Make sure the hose kit is in the proper location with the correct GPM.
2) Improper Balance of Manual Valve	2) Measure the flow through the AccuSetter venturi and re-balance the coil.
3) System Pressure is too High	3) Check the differential pressure across the AutoFlow valve. If for 2-32 psi, the differential pressure is larger than 32 psi, close the return side ball valve until the difference is less than 32 psi. The spring range on the cartridge could be changed to 5 - 60 which will also solve the problem.
4) AutoFlow Valve is Backward	4) Check the flow arrow and reverse the valve if necessary.

Problem: Noise and Vibration

Possible Cause	Possible Solution
1) Solenoid Shut-off Valve is causing "Water Hammer"	1) The solenoid valve may be closing too quickly, causing water hammer. Use a slower acting valve.
2) Water Noise	2) Check the hose kit size versus the ASHRAE recommended sizes in F318, page 9. Use a larger size if necessary.
3) AutoFlow valve is Clicking and Noisy	3a) Check the Delta P across the regulator and it may be necessary to replace the cartridge with a different spring range. 3b) Make sure the air is purged from the system. Air can cause a clicking noise.

Statement of Warranty

A “Limited Warranty” For Sales of Products Used In Consumer Applications.

FLOW DESIGN, INC. supplies products to you which may be used by you or others in consumer product applications. We wish to inform you of the scope of our warranty statement which is listed below. Because of its limitations and exclusions, our warranty must be designated a “limited” warranty for purposes of potential consumer uses of our products.

We warrant that our products will be of good merchantable quality, free from defects in material and workmanship, and will possess the characteristics represented in writing by us. Claim from breach of the above warranty must be made within the time specified below from the ship date to the Original User.

- **12 months - hoses and components**
- **60 months - brass/steel products**
(unless otherwise specified)

(All others please consult factory)

Some states do not allow limitations on how long implied warranty lasts, so the above limitations may not apply to you. Upon satisfactory proof of claim, we will, within a reasonable amount of time, make any necessary repairs, additions or corrections or, at our option, replace any defective parts free of charge. FDI is not responsible for field labor to remove defective products and/or reinstall replacement products. **All returned products must have a Return Material Authorization (RMA)**. The foregoing is in lieu of all other warranties, expressed or implied. This warranty statement sets forth the extent of our liability for breach of any warranty or deficiency in connection with the sale/use of the products.

It is understood that we will not be liable for consequential damages of any nature, including but not limited to loss of profit, delays or expenses, whether based on tort or contract nor does a delay in shipping constitute FDI the obligation to pay freight charges. (Some states do not allow the exclusion or limitation of incidental or consequential damages, so the above limitation or exclusion may not apply to you.) This warranty gives you specific legal rights, and you may also have other rights which vary from state to state.

NO REPRESENTATIVE OF FLOW DESIGN INC. HAS ANY AUTHORITY TO CHANGE OR EXTEND THE PROVISIONS OF THIS WARRANTY OR CONTRACT IN ANY MANNER WHATSOEVER.